

H SERIES

H 1500



Ordering-Example:

Special Sizes Available On Request.

OSAS + OSM = OVER STROKE ACTIVE SAFETY + OVER STROKE MARKER

ACTIVE SAFETY

The new code will be supplied only when the old will be out of stock

easuy MANIFOLD

* F_{1i} = Isothermal end force at 100% Cu

** F_{1p} = Polytrophic end force at 100% Cu



ACTIVE SAFETY

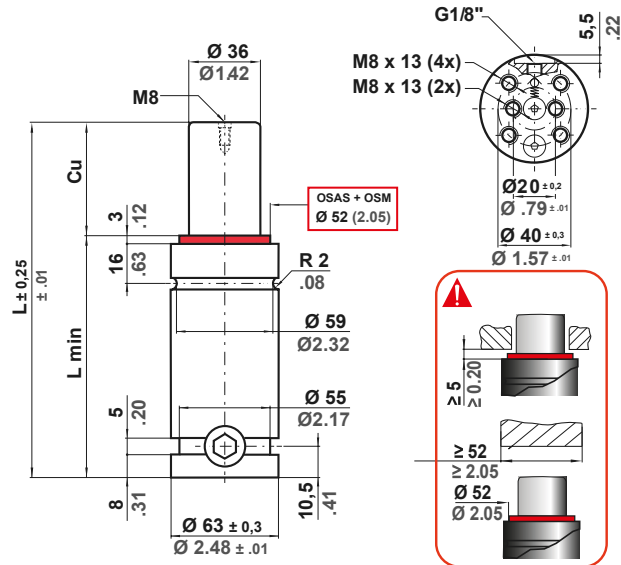

		0 - 80 °C 32 - 176 °F	ΔP ± 0.33 %/°C	P max 150 bar 2175 psi	P min 20 bar 290 psi	S 10,17 cm ² 1.576 in ²	SPM ~ 15 - 100 (at 20°C)	Max Speed 1.8 m/s 70.8 in/s	Maintenance kit 39BMH01500CH
--	--	--------------------------	---------------------------	-------------------------------------	-----------------------------------	--	---------------------------------------	--	--

CODE PHASING OUT from 04/2021	NEW	Cu		L		L min		F0 Initial force		F1i End force *		F1p End force **		V0		PED 2014/68/EU			
		mm	inch	mm	inch	mm	inch	daN	lb	daN	lb	daN	lb	cm ³	in ³	~Kg	~lb	✓	
H 1500 - 013 - C	◆ H 1500 - 013 - D	13	0.51	120,7	4.75	107,7	4.24	1530	3440	1982	4456	2260	5081	67	4.10	1,98	4.37	✓	
H 1500 - 025 - C	■ H 1500 - 025 - D	25	0,98	145	5.71	120	4.72			2177	4895	2560	5755	99	6.02	2,13	4.70	✓	
H 1500 - 038 - C	H 1500 - 038 - D	38	1,50	171	6.73	133	5.24			2306	5183	2762	6210	132	8.06	2,29	5.05	✓	
H 1500 - 050 - C	H 1500 - 050 - D	50	1,97	195	7.68	145	5.71			2383	5358	2887	6490	163	9.95	2,44	5.38	✓	
H 1500 - 063 - C	H 1500 - 063 - D	63	2,48	221	8.70	158	6.22			2443	5493	2983	6707	197	11.99	2,60	5.73	✓	
H 1500 - 075 - C	H 1500 - 075 - D	75	2,95	245	9.65	170	6.69			2484	5585	3050	6857	227	13.88	2,75	6.06	✓	
H 1500 - 080 - C	H 1500 - 080 - D	80	3,15	255	10.04	175	6.89			± 5%	2499	5617	3074	6910	240	14.66	2,81	6.19	✓
H 1500 - 100 - C	H 1500 - 100 - D	100	3,94	295	11.61	195	7.68			150 bar	2544	5720	3148	7078	292	17.80	3,03	6.68	✓
H 1500 - 125 - C	H 1500 - 125 - D	125	4,92	345	13.58	220	8.66			2175 psi	2584	5809	3214	7224	356	21.73	3,34	7.36	✓
H 1500 - 150 - C	H 1500 - 150 - D	150	5,91	395	15.55	245	9.65			+ 20 °C	2612	5873	3260	7329	420	25.65	3,64	8.02	✓
H 1500 - 160 - C	H 1500 - 160 - D	160	6,30	415	16.34	255	10.04			+68 °F	2621	5893	3275	7363	446	27.22	3,77	8.31	✓
H 1500 - 175 - C	H 1500 - 175 - D	175	6,89	445	17.52	270	10.63			2633	5920	3295	7408	485	29.58	3,95	8.71	✓	
H 1500 - 200 - C	H 1500 - 200 - D	200	7,87	495	19.49	295	11.61			2650	5957	3322	7469	549	33.51	4,26	9.39	✓	
H 1500 - 250 - C	H 1500 - 250 - D	250	9,84	595	23.43	345	13.58			2722	6119	3443	7740	661	40.36	4,99	11.00	✓	
H 1500 - 300 - C	H 1500 - 300 - D	300	11,81	695	27.36	395	15.55			2804	6303	3582	8052	764	46.59	5,81	12.81	✓	

◆ Disposable

