

H SERIES

H 2400



Ordering-Example:

Special Sizes Available On Request.

ISO 11901 - 1	VDI 3003 Blatt 4	B2 4008 (BMW)	075.90.65 (FCA)
39D 838 (VW)			



OSAS + OSM = OVER STROKE ACTIVE SAFETY + OVER STROKE MARKER

ACTIVE SAFETY



The new code will be supplied only when the old will be out of stock



* F_{1i} = Isothermal end force at 100% Cu

** F_{1p} = Polytrophic end force at 100% Cu

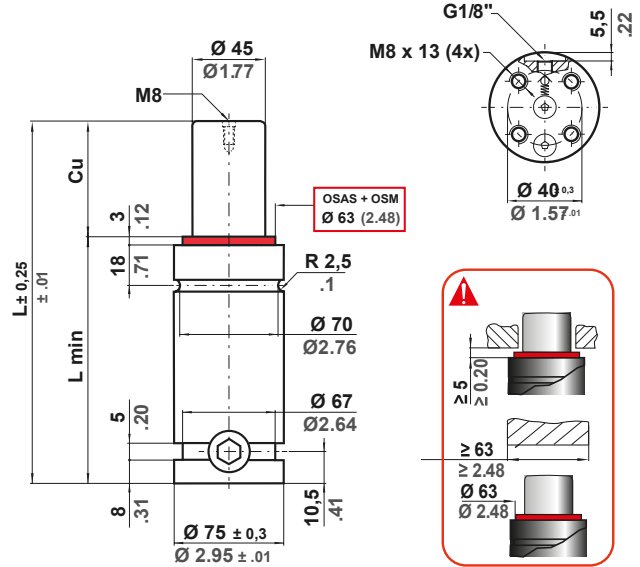

N2	0 - 80 °C 32 - 176 °F	ΔP ± 0.33 %/°C	P max 150 bar 2175 psi	P min 20 bar 290 psi	S 15,90 cm ² 2.465 in ²	SPM ~ 15 - 100 (at 20°C)	Max Speed 1.8 m/s 70.8 in/s	Maintenance kit 39BMH02400DH
----	--------------------------	---------------------------	-------------------------------------	-----------------------------------	--	---------------------------------------	--	--

CODE PHASING OUT from 04/2021	NEW	Cu		L		L min		F0 Initial force		F1i End force *		F1p End force **		V0		~Kg	~lb	PED 2014/68/EU
		mm	inch	mm	inch	mm	inch	daN	lb	daN	lb	daN	lb	cm ³	in ³			
H 2400 - 025 - D	◆ H 2400 - 025 - E	25	0.98	160	6.30	135	5.31			3282	7378	3814	8574	169	10.32	3,34	7.36	✓
H 2400 - 038 - D	■ H 2400 - 038 - E	38	1.50	186	7.32	148	5.83			3495	7857	4146	9321	220	13.44	3,55	7.83	✓
H 2400 - 050 - D	H 2400 - 050 - E	50	1.97	210	8.27	160	6.30			3632	8165	4363	9807	267	16.31	3,75	8.27	✓
H 2400 - 063 - D	H 2400 - 063 - E	63	2.48	236	9.31	173	6.81			3741	8410	4537	10200	318	19.42	3,96	8.73	✓
H 2400 - 075 - D	H 2400 - 075 - E	75	2.95	260	10.24	185	7.28			3818	8583	4662	10480	366	22.30	4,15	9.15	✓
H 2400 - 080 - D	H 2400 - 080 - E	80	3.15	270	10.63	190	7.48	2385 5362	± 5% 150 bar 2175 psi + 20 °C +68 °F	3845	8644	4706	10579	385	23.50	4,23	9.33	✓
H 2400 - 100 - D	H 2400 - 100 - E	100	3.94	310	12.20	210	8.27			3933	8842	4850	10902	464	28.29	4,51	9.94	✓
H 2400 - 125 - D	H 2400 - 125 - E	125	4.92	360	14.17	235	9.25			4012	9019	4979	11192	562	34.28	4,91	10.82	✓
H 2400 - 150 - D	H 2400 - 160 - E	150	5.91	410	16.14	260	10.24			4068	9146	5072	11402	660	40.28	5,32	11.73	✓
H 2400 - 160 - D	H 2400 - 160 - E	160	6.30	430	16.93	270	10.63			4087	9187	5103	11471	699	42.68	5,49	12.10	✓
H 2400 - 175 - D	H 2400 - 175 - E	175	6.89	460	18.11	285	11.22			4111	9243	5144	11563	758	46.27	5,73	12.63	✓
H 2400 - 200 - D	H 2400 - 200 - E	200	7.87	510	20.08	310	12.20			4145	9319	5200	11690	856	52.26	6,14	13.54	✓
H 2400 - 200 - D	H 2400 - 250 - E	250	9.84	610	24.02	360	14.17			4195	9431	5283	11876	1053	64.25	6,95	15.32	✓
H 2400 - 275 - D	H 2400 - 275 - E	275	10.83	660	25.98	385	15.16			4214	9473	5314	11947	1151	70.24	7,36	16.23	✓
H 2400 - 300 - D	H 2400 - 300 - E	300	11.81	710	27.95	410	16.14			4230	9509	5341	12007	1249	76.22	7,77	17.13	✓

◆ Disposable

