

## RT SERIES

### RT 1000



Ordering-Example:

Special Sizes Available On Request.

K 32 R (Nissan)	E24.54.815.G (PSA)	EM24.54.700 (Renault)
SMS DNH 3203n Rev.3 (TOYOTA)		

**OSAS + OSM** = OVER STROKE ACTIVE SAFETY + OVER STROKE MARKER

**ACTIVE SAFETY**

The new code will be supplied only when the old will be out of stock

\*  $F_{1i}$  = Isothermal end force at 100% Cu

\*\*  $F_{1p}$  = Polytrophic end force at 100% Cu



ACTIVE SAFETY

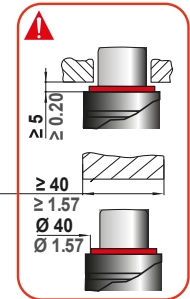
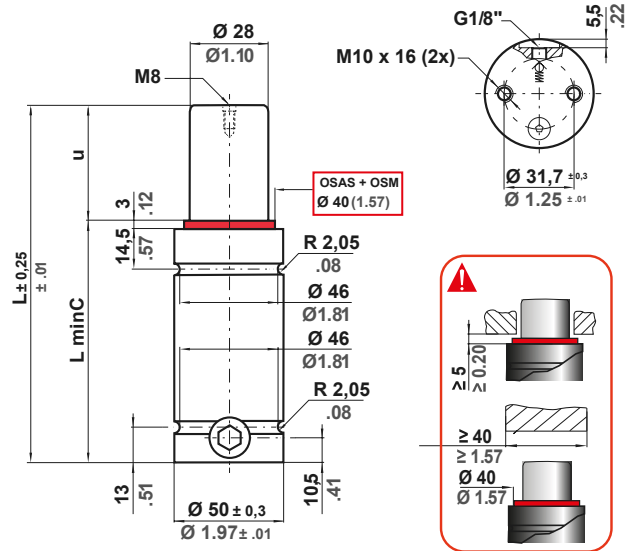

N2	0 - 80 °C 32 - 176 °F	$\Delta P$ ± 0,33 %/°C	<b>P max</b> 150 bar 2175 psi	<b>P min</b> 20 bar 290 psi	<b>S</b> 6,15 cm <sup>2</sup> 0,953 in <sup>2</sup>	<b>SPM</b> ~ 20 - 100 (at 20°C)	<b>Max Speed</b> 1,8 m/s 70,8 in/s	<b>Maintenance kit</b> 39BMRV01000C
----	--------------------------	---------------------------	-------------------------------------	-----------------------------------	---	---------------------------------------	--	--

CODE PHASING OUT from 04/2021	NEW	Cu		L		L min		F0 Initial force		F1i End force *		F1p End force **		V0		PED 2014/68/EU		
		mm	inch	mm	inch	mm	inch	daN	lb	daN	lb	daN	lb	cm <sup>3</sup>	in <sup>3</sup>	~Kg	~lb	
RT 1000 - 010 - A	♦RT 1000 - 010 - B	10	0.39	72	2.83	62	2.44			1282	2883	1495	3329	25,5	1,56	0,68	1,50	✓
RT 1000 - 013 - A	♦RT 1000 - 013 - B	13	0.51	78	3.07	65	2.56			1332	2995	1572	3500	30,2	1,84	0,70	1,54	✓
RT 1000 - 016 - A	RT 1000 - 016 - B	16	0.63	84	3.31	68	2.68			1371	3082	1633	3635	34,9	2,13	0,73	1,61	✓
RT 1000 - 019 - A	RT 1000 - 019 - B	19	0.75	90	3.54	71	2.80			1402	3151	1682	3745	39,6	2,42	0,75	1,65	✓
RT 1000 - 025 - A	RT 1000 - 025 - B	25	0.98	102	4.02	77	3.03	920	2068	1448	3255	1756	3909	48,9	2,98	0,80	1,76	✓
RT 1000 - 032 - A	RT 1000 - 032 - B	32	1.26	116	4.57	84	3.31			1486	3340	1817	4047	59,8	3,65	0,86	1,90	✓
RT 1000 - 038 - A	RT 1000 - 038 - B	38	1.50	128	5.04	90	3.54	± 5%	150 bar 2175 psi	1510	3394	1856	4132	69,2	4,22	0,90	1,98	✓
RT 1000 - 050 - A	RT 1000 - 050 - B	50	1.97	152	5.98	102	4.02			1543	3469	1911	4256	87,9	5,36	1,00	2,20	✓
RT 1000 - 063 - A	RT 1000 - 063 - B	63	2.48	178	7.01	115	4.53	+ 20 °C +68 °F		1567	3523	1951	4346	108,1	6,60	1,10	2,43	✓
RT 1000 - 075 - A	RT 1000 - 075 - B	75	2.95	202	7.95	127	5.00			1583	3559	1977	4404	126,8	7,74	1,20	2,65	✓
RT 1000 - 080 - A	RT 1000 - 080 - B	80	3.15	212	8.35	132	5.20			1588	3571	1986	4424	134,6	8,21	1,24	2,73	✓
RT 1000 - 100 - A	RT 1000 - 100 - B	100	3.94	252	9.92	152	5.98			1605	3608	2013	4485	165,8	10,12	1,40	3,09	✓
RT 1000 - 125 - A	RT 1000 - 125 - B	125	4.92	302	11.89	177	6.97			1619	3639	2036	4537	204,7	12,49	1,60	3,53	✓

♦ Disposable

