

## SC SERIES

### SC 150



Ordering-Example:

Special Sizes Available On Request.

075.90.55 (FCA)	B2 4006 (BMW)	B8 3180 220 000 001(MB)	E24.54.815.G (PSA)
EM24.54.700 (Renault)			



**OSAS + OSM** = OVER STROKE ACTIVE SAFETY + OVER STROKE MARKER

#### ACTIVE SAFETY



OSAS



USAS



OPAS

The new code will be supplied only when the old will be out of stock



\*  $F_{1i}$  =  
Isothermal  
end force  
at 100% Cu

\*\*  $F_{1p}$  =  
Polytrophic  
end force  
at 100% Cu

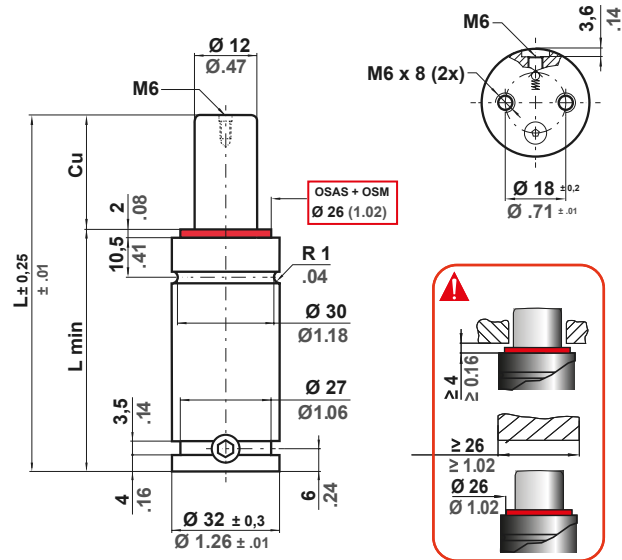

N2	0 - 80 °C 32 - 176 °F	$\Delta P$ ± 0.33 %/°C	<b>P max</b> 150 bar 2175 psi	<b>P min</b> 20 bar 290 psi	<b>S</b> 1.13 cm <sup>2</sup> 0.175 in <sup>2</sup>	<b>SPM</b> ~ 80 - 100 (at 20°C)	<b>Max Speed</b> 1.8 m/s 70.8 in/s	<b>Maintenance kit</b> 39BMS00150E
----	--------------------------	---------------------------	-------------------------------------	-----------------------------------	---	---------------------------------------	--	---------------------------------------

CODE PHASING OUT from 04/2021	NEW	Cu		L		L min		F0 Initial force		F1i End force *		F1p End force **		V0		PED 2014/68/EU		
		mm	inch	mm	inch	mm	inch	daN	lb	daN	lb	daN	lb	cm <sup>3</sup>	in <sup>3</sup>		~Kg	~lb
SC 150 - 010 - D	◆ SC 150 - 010 - E	10	0.39	70	2.76	60	2.36			192	431	209	469	11,6	0.71	0,28	0.62	✓
SC 150 - 013 - D	◆ SC 150 - 013 - E	12,7	0.51	75,2	2.97	62,7	2.47			195	438	213	479	13,1	0.80	0,29	0.64	✓
SC 150 - 016 - D	SC 150 - 016 - E	16	0.63	82	3.23	66	2.60			198	445	218	490	14,8	0.90	0,30	0.66	✓
SC 150 - 025 - D	SC 150 - 025 - E	25	0.98	100	3.94	75	2.95			203	457	226	508	20,0	1.22	0,33	0.73	✓
SC 150 - 038 - D	SC 150 - 038 - E	38	1.50	126	4.96	88	3.46	170	382	208	467	233	523	27,3	1.67	0,36	0.79	✓
SC 150 - 050 - D	SC 150 - 050 - E	50	1.97	150	5.91	100	3.94	± 5% 150 bar 2175 psi + 20 °C +68 °F		211	473	237	532	34,1	2.08	0,40	0.88	✓
SC 150 - 063 - D	SC 150 - 063 - E	63,5	2.48	177	6.97	113,5	4.47			212	478	239	538	41,7	2.54	0,44	0.97	✓
SC 150 - 080 - D	SC 150 - 080 - E	80	3.15	210	8.27	130	5.12			214	481	242	544	50,9	3.11	0,49	1.08	✓
SC 150 - 100 - D	SC 150 - 100 - E	100	3.94	250	9.84	150	5.91			216	485	245	550	61,6	3.76	0,55	1.21	✓
SC 150 - 125 - D	SC 150 - 125 - E	125	4.92	300	11.81	175	6.89			218	490	247	556	74,7	4.56	0,64	1.41	✓

◆ Disposable

