

S SERIES

S 1500



Ordering-Example:

Special Sizes Available On Request.

EM24.54.700 (Renault)



OSAS + OSM

OVER STROKE = ACTIVE SAFETY + OVER STROKE MARKER

ACTIVE SAFETY



OSAS



USAS



OPAS

The new code will be supplied only when the old will be out of stock

easu
MANIFOLD

* F_{1i} =

Isothermal end force at 100% Cu

** F_{1p} =

Polytropic end force at 100% Cu

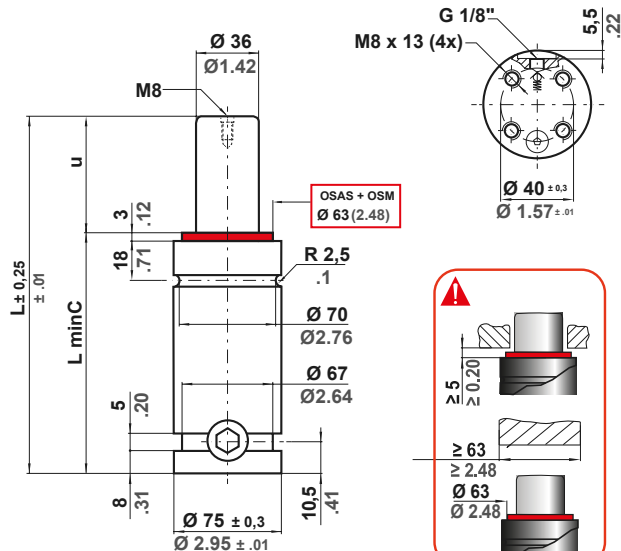

		0 - 80 °C 32 - 176 °F	ΔP ± 0.33 %/°C	P max 150 bar 2175 psi	P min 20 bar 290 psi	S 10,18 cm ² 1.578 in ²	SPM ~ 20 - 80 (at 20°C)	Max Speed 1.8 m/s 70.8 in/s	Maintenance kit 39BMS01500B
--	--	--------------------------	---------------------------	-------------------------------------	-----------------------------------	--	--------------------------------------	--	---------------------------------------

CODE PHASING OUT from 04/2021	NEW	Cu		L		L min		F0 Initial force		F1i End force *		F1p End force **		V0		~Kg	~lb	PED 2014/68/EU	
		mm	inch	mm	inch	mm	inch	daN	lb	daN	lb	daN	lb	cm ³	in ³				
S 1500 - 025 - A	S 1500 - 025 - B	25	0.98	110	4.33	85	3.35	± 5% 150 bar 2175 psi + 20 °C +68 °F	1530	3440	2238	5031	2655	5969	93	5.65	2,25	4.96	✓
S 1500 - 038 - A	S 1500 - 038 - B	38	1.50	136	5.35	98	3.86		2319	5214	2784	6258	131	7.97	2,53	5.58	✓		
S 1500 - 050 - A	S 1500 - 050 - B	50	1.97	160	6.30	110	4.33		2363	5312	2854	6416	166	10.11	2,78	6.13	✓		
S 1500 - 063 - A	S 1500 - 063 - B	63	2.48	186	7.32	123	4.84		2395	5383	2905	6530	204	12.43	3,06	6.75	✓		
S 1500 - 080 - A	S 1500 - 080 - B	80	3.15	220	8.66	140	5.51		2422	5445	2949	6630	253	15.46	3,42	7.54	✓		
S 1500 - 100 - A	S 1500 - 100 - B	100	3.94	260	10.24	160	6.30		2444	5494	2984	6708	312	19.03	3,84	8.47	✓		

◆ Disposable

