

Ordering-Example:

Special Sizes Available On Request.

MB	Renault	Suzuki
----	---------	--------

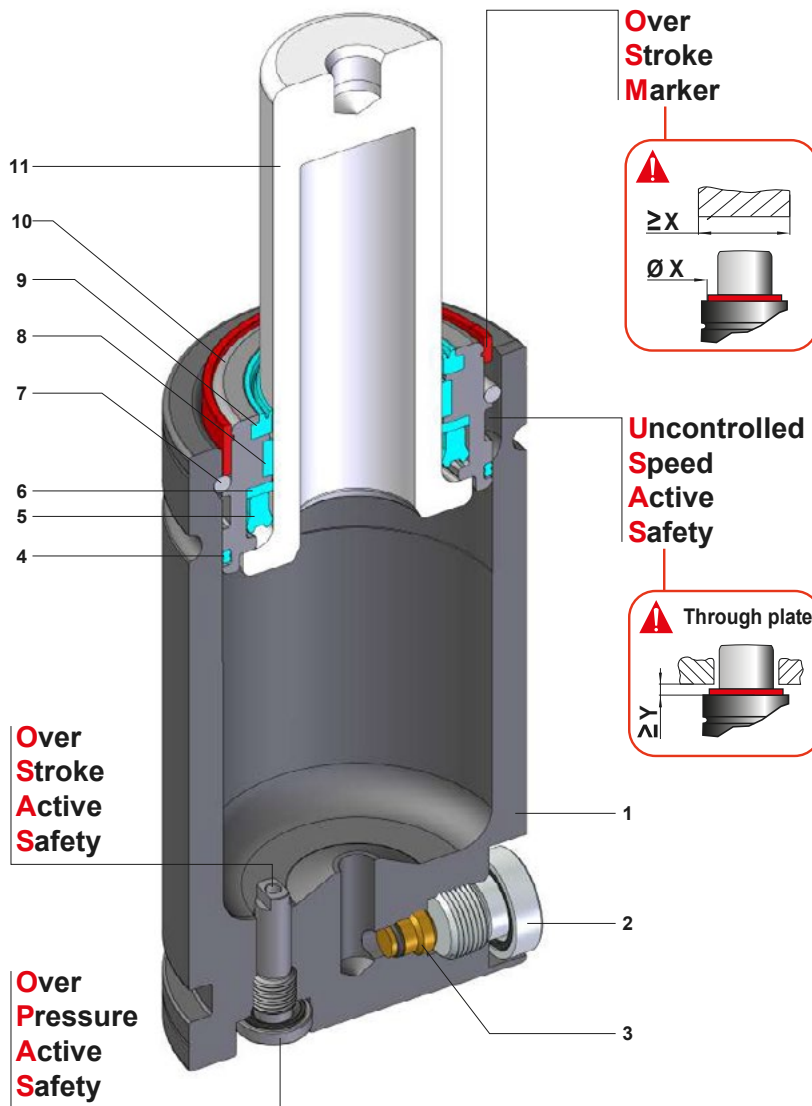

ISO forces, reduced height

SEALING	ROD SEAL
DESIGN	BUSH - BODY DESIGN

1	Body	5	Rod seal	9	Rod wiper
2	Plug	6	Back-up ring	10	Bush
3	Valve	7	Retaining ring	11	Rod (nitrited superfinished)
4	Dual ring seal	8	Guide ring		

Ordering-Example:  
S 750-050-B-E-W

Special Sizes Available On Request.

### RANGE CHART

Model	Body Ø		Stroke Cu		Initial force F0						
	mm	inch	mm	inch	daN	lb	OSAS	USAS	OPAS	SKUDO	SW
S 500	45	1.77	6 - 125	0.24 - 4.92	470	1057	✓	✓	✓	-	✓
S 750	50	1.97	6 - 125	0.24 - 4.92	740	1664	✓	✓	✓	-	✓
S 1500	75	2.95	25 - 100	0.98 - 3.94	1530	3440	✓	✓	✓	-	✓
S 3000	95	3.74	25 - 100	0.98 - 3.94	2945	6621	✓	✓	✓	-	✓

✓ Built-in as standard    ✓ Optional upon request

### HOW TO ORDER

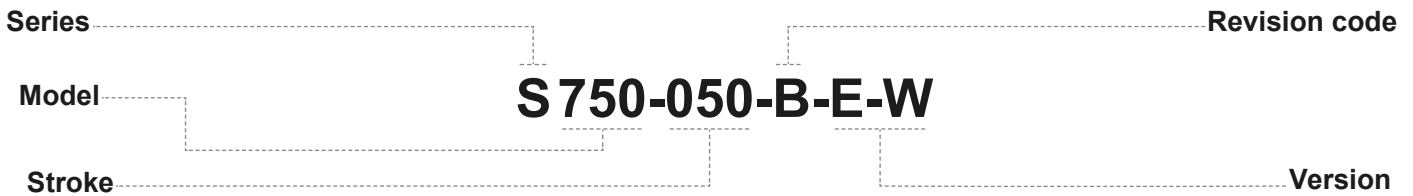

### Available versions

<b>S 750-050-CS</b> Standard code	<b>750-050-C-W</b> Add "-W" to standard code	<b>S 750-050-C-N</b> Add "-N" to standard code	<b>S 750-050-C-N-W</b> Add "-N-W" to standard code	<b>S 750-050-B-E</b> Add "-E" to standard code	<b>S 750-050-B-E-W</b> Add "-E-W" to standard code
Self contained	Self contained + Secondary wiper	Linkable	Linkable + Secondary wiper	Easy Manifold	Easy Manifold + Secondary wiper