

RG SERIES

Nissan	Renault	
--------	---------	--

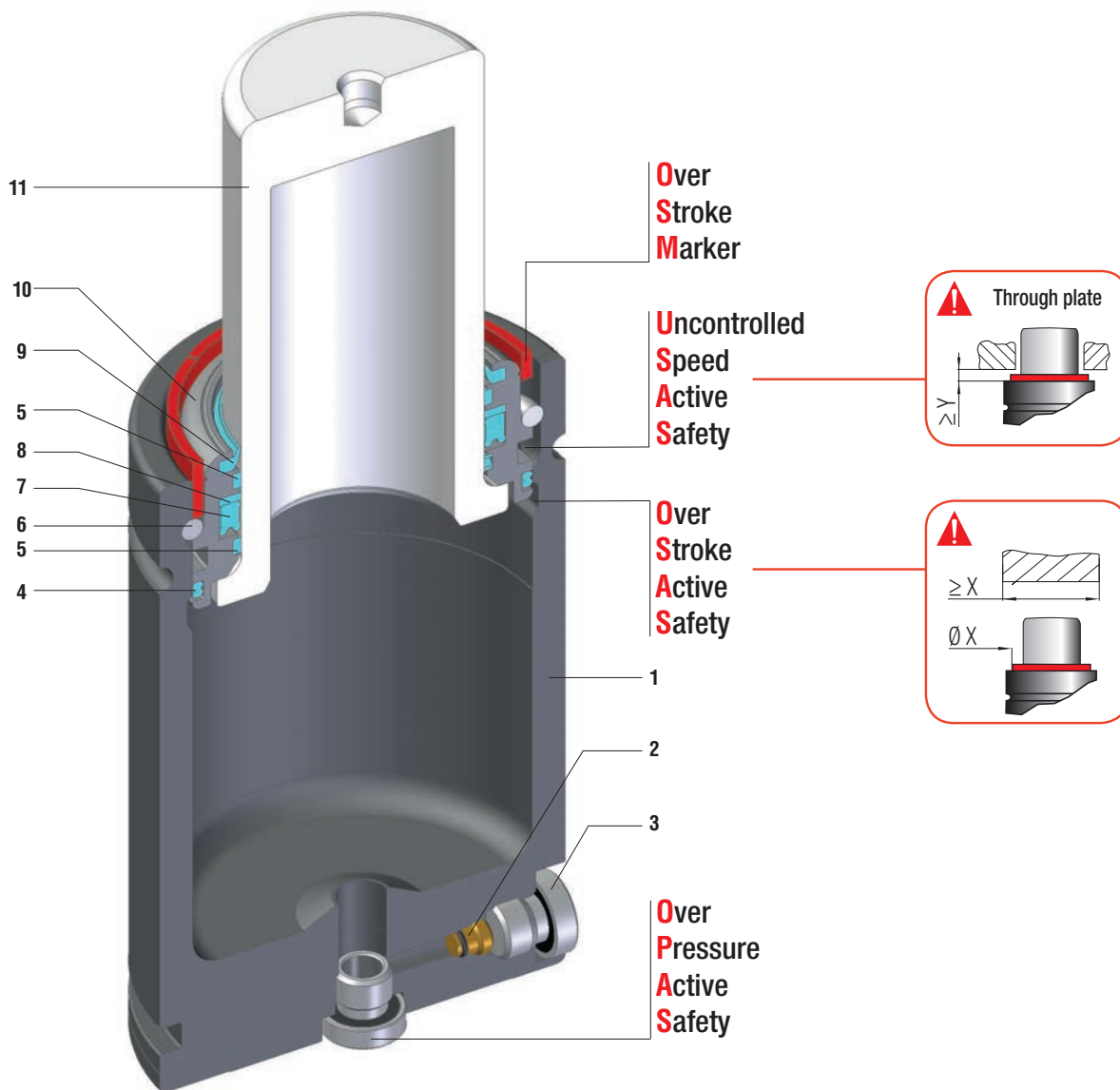

Minima altezza, massima forza, collegabili G1/8 - Minimum height, maximum force, hose cylinders with G1/8 charging port - Minimale Höhe, maximale Kraft, Gdf. mit G1/8 Öffnung verbindbar - Hauteur minimale, force maximale, cylindres raccordés avec trou G1/8 gaz - Mínima altura, máxima fuerza, cilindros conectados con agujero G1/8 gas - Altura mínima, força máxima, cilindros conectados com furo G1/8 gás

SEALING	ROD SEAL
DESIGN	BUSH - BODY DESIGN

1	Body	5	Guide ring	9	Rod wiper
2	Valve	6	Retaining ring	10	Bush
3	Plug	7	Rod seal	11	Rod (nitrited superfinished)
4	Dual ring seal	8	Back-up ring		

RANGE CHART

Model	Body Ø		Stroke Cu		Initial force F0						
	mm	inch	mm	inch	daN	lb	OSAS	USAS	OPAS	SKUDO	SW
RG 750	45	1.77	10 - 125	0.39 - 4.92	740	1664	✓	✓	✓	-	✓
RG 1000	50	1.97	10 - 125	0.39 - 4.92	920	2068	✓	✓	✓	-	✓
RG 1500	63	2.48	10 - 125	0.39 - 4.92	1530	3440	✓	✓	✓	-	✓
RG 2400	75	2.95	10 - 125	0.39 - 4.92	2385	5362	✓	✓	✓	-	✓
RG 4200	95	3.74	16 - 125	0.63 - 4.92	4240	9532	✓	✓	✓	-	✓
RG 6600	120	4.72	16 - 125	0.63 - 4.92	6630	14905	✓	✓	✓	-	✓

Built-in as standard
 Optional upon request

HOW TO ORDER



Available versions

RG 2400-050-A Standard code	RG 2400-050-A-W Add "-W" to standard code	RG 2400-050-A-N Add "-N" to standard code	RG 2400-050-A-N-W Add "-N-W" to standard code	RG 2400-050-A-E Add "-E" to standard code	RG 2400-050-A-E-W Add "-E-W" to standard code
Self contained	Self contained + Secondary wiper	Linkable	Linkable + Secondary wiper	Easy Manifold	Easy Manifold + Secondary wiper