

MB	Renault	Suzuki

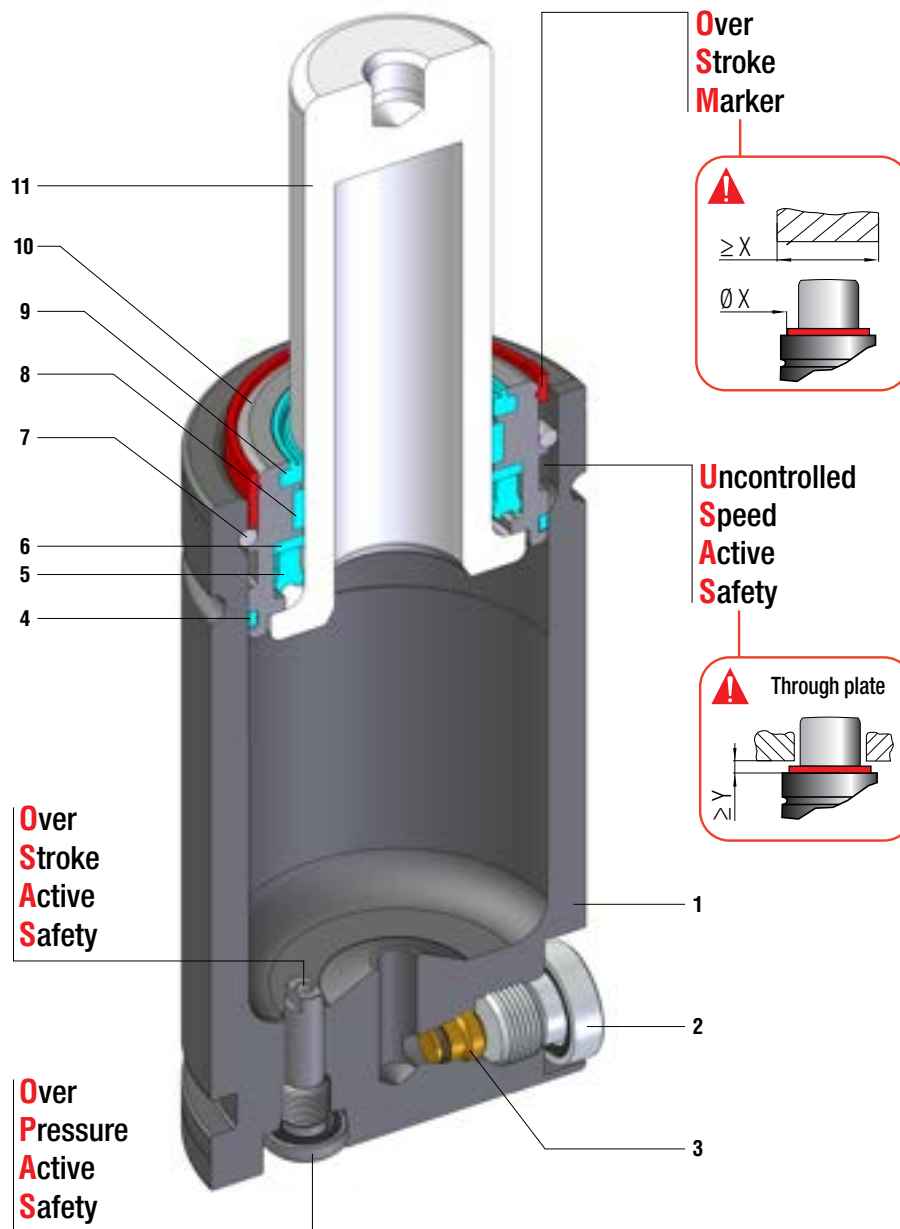

Forze ISO, altezza ridotta - ISO forces, reduced height - ISO Kräfte, Reduzierte Höhe  
 Forces ISO, Hauteur réduite - Fuerzas ISO, altura reducida - Forças ISO, altura reduzida

<b>SEALING</b>	ROD SEAL
<b>DESIGN</b>	BUSH - BODY DESIGN

<b>1</b>	Body	<b>5</b>	Rod seal	<b>9</b>	Rod wiper
<b>2</b>	Plug	<b>6</b>	Back-up ring	<b>10</b>	Bush
<b>3</b>	Valve	<b>7</b>	Retaining ring	<b>11</b>	Rod (nitrited superfinished)
<b>4</b>	Dual ring seal	<b>8</b>	Guide ring		



### RANGE CHART

Model	Body Ø		Stroke Cu		Initial force F0						
	mm	inch	mm	inch	daN	lb	OSAS	USAS	OPAS	SKUDO	SW
■ S 500	45	1.77	6 - 125	0.24 - 4.92	470	1057	✓	✓	✓	-	✓
■ S 750	50	1.97	6 - 125	0.24 - 4.92	740	1664	✓	✓	✓	-	✓
■ S 1500	75	2.95	25 - 100	0.98 - 3.94	1530	3440	✓	✓	✓	-	✓
■ S 3000	95	3.74	25 - 100	0.98 - 3.94	2945	6621	✓	✓	✓	-	✓

✓ Built-in as standard      ✓ Optional upon request

### HOW TO ORDER

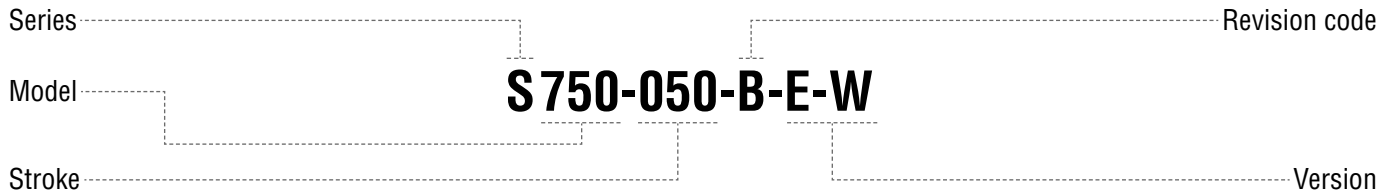

#### Available versions

<b>S 750-050-C</b> Standard code	<b>S 750-050-C-W</b> Add "-W" to standard code	<b>S 750-050-C-N</b> Add "-N" to standard code	<b>S 750-050-C-N-W</b> Add "-N-W" to standard code	<b>S 750-050-B-E</b> Add "-E" to standard code	<b>S 750-050-B-E-W</b> Add "-E-W" to standard code
Self contained	Self contained	Linkable	Linkable	Easy Manifold	Easy Manifold
	+  Secondary wiper		+  Secondary wiper		+  Secondary wiper