

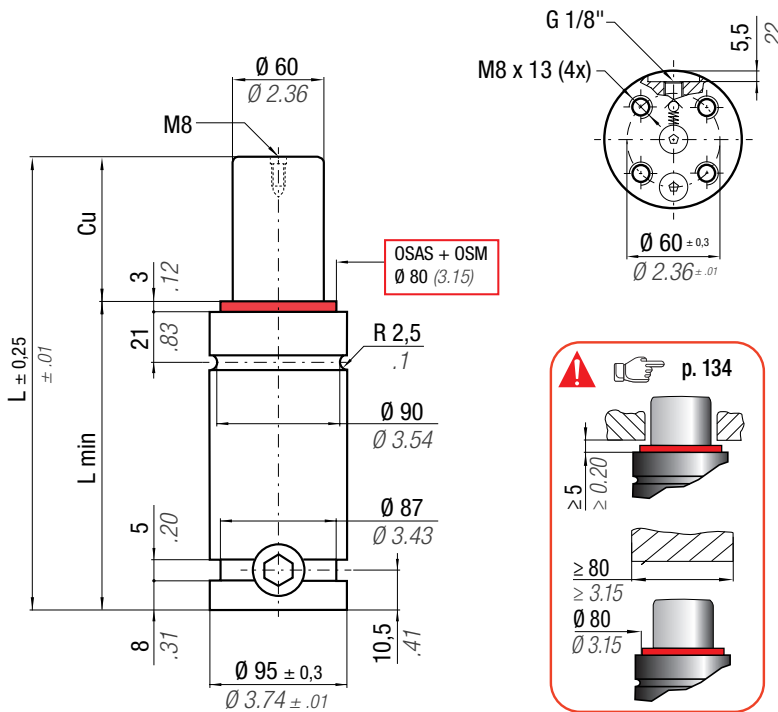

ISO 11901 - 4 39D 838 (VW)	VDI 3003 Blatt 4	B2 4008 (BMW)	075.90.65 (FCA)
-------------------------------	------------------	---------------	-----------------

**H 4200**



**OSAS + OSM** = OVER STROKE ACTIVE SAFETY + OVER STROKE MARKER



Il nuovo codice sarà fornito solo ad esaurimento del vecchio  
 The new code will be supplied only when the old will be out of stock  
 Der neue Kode wird nur angegeben, wenn der alte nicht mehr lieferbar ist  
 Le nouveau code sera fourni uniquement lorsque le vieux stock sera écoulé  
 El nuevo código será suministrado sólo cuando se agoten las existencias del antiguo  
 O novo código irá ser fornecido apenas quando o antigo esgotar stock

**ACTIVE SAFETY**



OSAS



USAS



OPAS



\*  $F_{1i}$  =

Isothermal end force at 100% Cu

\*\*  $F_{1p}$  =

Polytrophic end force at 100% Cu

N <sub>2</sub>	0 - 80 °C 32 - 176 °F	$\Delta P$ ± 0,33 %/°C	P max 150 bar 2175 psi	P min 20 bar 290 psi	S 28,27 cm <sup>2</sup> 4.382 in <sup>2</sup>	SPM ~ 15 - 100 (at 20°C)	Max Speed 1,8 m/s 70.8 in/s	Maintenance kit 39BMH04200D Cu 25 ÷ 80 39BMH04200DH Cu 100 ÷ 300
----------------	--------------------------	---------------------------	------------------------------	----------------------------	---	--------------------------------	-----------------------------------	--

CODE PHASING OUT from 04/2021	NEW	Cu		L		L min		F <sub>0</sub> Initial force		F <sub>1i</sub> * End force *		F <sub>1p</sub> ** End force **		V <sub>0</sub>		PED 2014/68/EU		
		mm	inch	mm	inch	mm	inch	daN	lb	daN	lb	daN	lb	cm <sup>3</sup>	in <sup>3</sup>		~Kg	~lb
H 4200 - 025 - D	H 4200 - 025 - E	25	0.98	170	6.69	145	5.71	4240 9532 ± 5%	150 bar 2175 psi	5877	13212	6846	15389	295	17.99	5,76	12.70	✓
H 4200 - 038 - D	H 4200 - 038 - E	38	1.50	196	7.72	158	6.22			6312	14190	7526	16919	378	23.09	6,12	13.49	✓
H 4200 - 050 - D	H 4200 - 050 - E	50	1.97	220	8.66	170	6.69			6601	14840	7987	17955	455	27.79	6,45	14.22	✓
H 4200 - 063 - D	H 4200 - 063 - E	63	2.48	246	9.70	183	7.20			6838	15371	8369	18815	539	32.88	6,80	14.99	✓
H 4200 - 075 - D	H 4200 - 075 - E	75	2.95	270	10.63	195	7.68			7008	15755	8648	19441	616	37.58	7,13	15.72	✓
H 4200 - 080 - D	H 4200 - 080 - E	80	3.15	280	11.02	200	7.87			7069	15892	8748	19666	648	39.54	7,27	16.03	✓
H 4200 - 100 - D	H 4200 - 100 - E	100	3.94	320	12.60	220	8.66			7269	16342	9078	20408	777	47.38	7,76	17.11	✓
H 4200 - 125 - D	H 4200 - 125 - E	125	4.92	370	14.57	245	9.65			7447	16742	9374	21074	938	57.22	8,45	18.63	✓
H 4200 - 150 - D	H 4200 - 150 - E	150	5.91	420	16.54	270	10.63			7581	17043	9599	21578	1098	67.02	9,13	20.13	✓
H 4200 - 160 - D	H 4200 - 160 - E	160	6.30	440	17.32	280	11.02			7656	17211	9724	21861	1156	70.56	9,40	20.72	✓
H 4200 - 175 - D	H 4200 - 175 - E	175	6.89	470	18.50	295	11.61	7712	17338	9820	22077	1253	76.44	9,82	21.65	✓		
H 4200 - 200 - D	H 4200 - 200 - E	200	7.87	520	20.47	320	12.60	7791	17515	9953	22376	1413	86.24	10,50	23.15	✓		
H 4200 - 250 - D	H 4200 - 250 - E	250	9.84	620	24.41	370	14.57	7908	17777	10151	22821	1734	105.83	11,87	26.17	✓		
H 4200 - 300 - D	H 4200 - 300 - E	300	11.81	720	28.35	420	16.54	8123	18260	10519	23648	2016	123.02	13,24	29.19	✓		

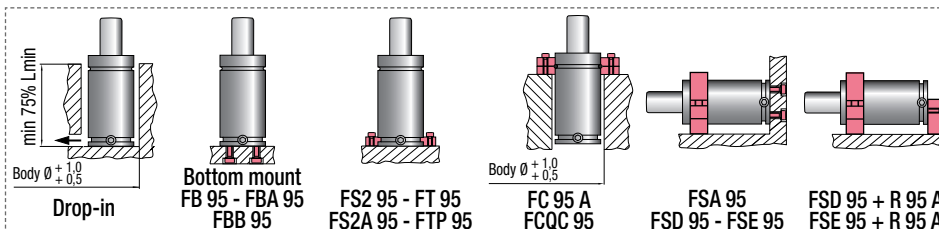

**HOW TO ORDER**



**INSTALLATION GUIDELINE**

