

## RV 750

ISO 11901 - 3 B8 3180 220 000 004(MB)	VDI 3003 - Blatt 3 E24.54.815.G (PSA)	B2 4005 (BMW) 39D 997 (VW)	W-DX35-6204 (Ford)
------------------------------------------	------------------------------------------	-------------------------------	--------------------



**OSAS + OSM** = OVER STROKE ACTIVE SAFETY + OVER STROKE MARKER

### ACTIVE SAFETY

Il nuovo codice sarà fornito solo ad esaurimento del vecchio

The new code will be supplied only when the old will be out of stock

Der neue Kode wird nur angegeben, wenn der alte nicht mehr lieferbar ist

Le nouveau code sera fourni uniquement lorsque le vieux stock sera écoulé

El nuevo código será suministrado sólo cuando se agoten las existencias del antiguo

O novo código irá ser fornecido apenas quando o antigo esgotar stock

**easu** p. 247

\*  $F_{1i}$  = Isothermal end force at 100% Cu p. 16

\*\*  $F_{1p}$  = Polytropic end force at 100% Cu

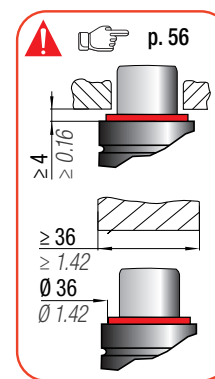
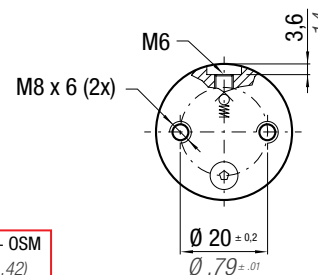
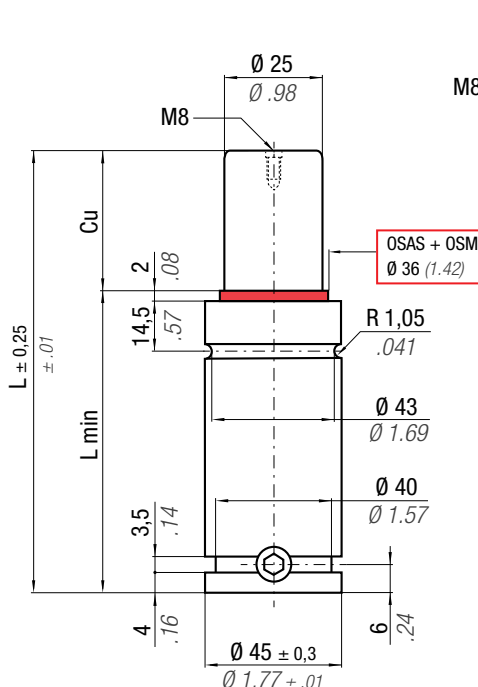

N <sub>2</sub>	0 - 80 °C 32 - 176 °F	$\Delta P$ ± 0,33 %/°C	P max 150 bar 2175 psi	P min 20 bar 290 psi	S 4,91 cm <sup>2</sup> 0,761 in <sup>2</sup>	SPM ~ 20 - 100 (at 20°C)	Max Speed 1,8 m/s 70,8 in/s	Maintenance kit 39BMRV00750C
----------------	--------------------------	---------------------------	------------------------------	----------------------------	----------------------------------------------------	--------------------------------	-----------------------------------	---------------------------------

CODE PHASING OUT from 04/2021	NEW	Cu	L	L min	F <sub>0</sub>	F <sub>1i</sub> *	F <sub>1p</sub> **	V <sub>0</sub>	PED 2014/68/EU							
mm	inch	mm	inch	mm	inch	daN	lb	daN	lb	cm <sup>3</sup>	in <sup>3</sup>	~Kg	~lb			
RV 750 - 010 - A	♦ RV 750 - 010 - B	10	0.39	52	2.05	42	1.65	1118	2514	1343	3018	16,6	1,01	0,36	0,79	✓
RV 750 - 013 - A	RV 750 - 013 - B	13	0.51	58	2.28	45	1.77	1152	2590	1396	3139	20,4	1,24	0,38	0,84	✓
RV 750 - 016 - A	RV 750 - 016 - B	16	0.63	64	2.52	48	1.89	1176	2644	1435	3227	24,1	1,47	0,40	0,88	✓
RV 750 - 019 - A	RV 750 - 019 - B	19	0.75	70	2.76	51	2.01	1194	2685	1465	3293	27,9	1,70	0,42	0,93	✓
RV 750 - 025 - A	RV 750 - 025 - B	25	0.98	82	3.23	57	2.24	1220	2743	1507	3388	35,5	2,17	0,45	0,99	✓
RV 750 - 032 - A	RV 750 - 032 - B	32	1.26	96	3.78	64	2.52	1240	2787	1539	3460	44,3	2,70	0,50	1,10	✓
RV 750 - 038 - A	RV 750 - 038 - B	38	1.50	108	4.25	70	2.76	1251	2813	1558	3503	51,9	3,17	0,54	1,19	✓
RV 750 - 050 - A	RV 750 - 050 - B	50	1.97	132	5.20	82	3.23	1267	2848	1584	3562	67,0	4,09	0,61	1,34	✓
RV 750 - 063 - A	RV 750 - 063 - B	63	2.48	158	6.22	95	3.74	1278	2873	1602	3602	83,4	5,09	0,70	1,54	✓
RV 750 - 075 - A	RV 750 - 075 - B	75	2.95	182	7.17	107	4.21	1285	2888	1614	3628	98,5	6,01	0,78	1,72	✓
RV 750 - 080 - A	RV 750 - 080 - B	80	3.15	192	7.56	112	4.41	1287	2893	1618	3637	104,8	6,40	0,81	1,79	✓
RV 750 - 100 - A	RV 750 - 100 - B	100	3.94	232	9.13	132	5.20	1294	2909	1629	3663	130,1	7,94	0,94	2,07	✓
RV 750 - 125 - A	RV 750 - 125 - B	125	4.92	282	11.10	157	6.18	1300	2922	1639	3685	161,6	9,86	1,10	2,43	✓

♦ Disposable

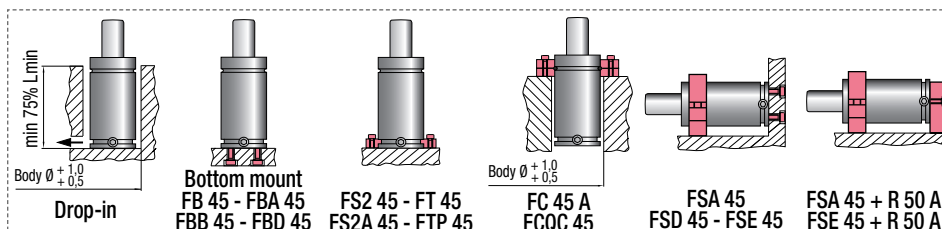

### HOW TO ORDER



### INSTALLATION GUIDELINE

