

## F - AU

### BUILT-IN CYLINDER

Special Sizes Available On Request.

3D Insertion Reference

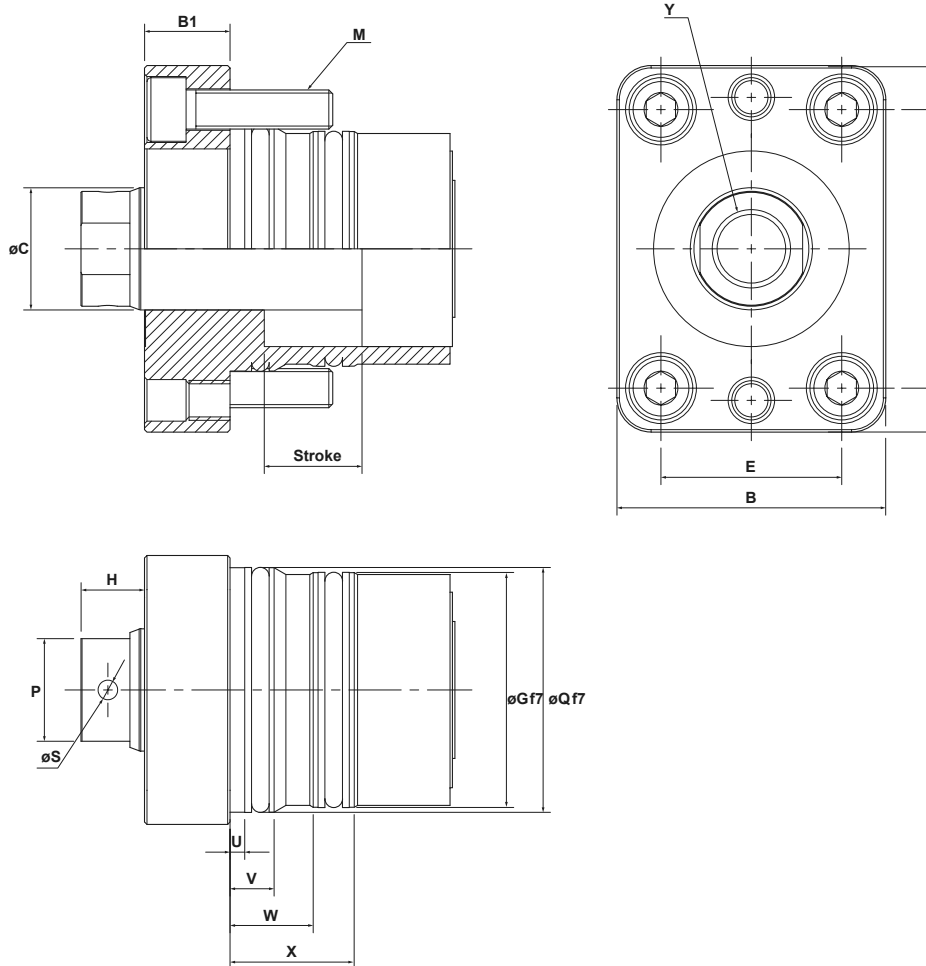

#### HOW TO ORDER

Reference: **F0AU40-15**

TYPE	OPERATION MODE	FIXA-TION	PISTON ø	STROKE ±0.1 (1)		A	B	B1	C	D	E	G
				MIN.	MAX.							
E	0	AU	025	010	050	55	40	13.5	16	42	27	34.1
			032	010	065	65	47	13.5	20	50	32	40.5
			040	010	080	75	55	17.5	25	57	37	48.1
			050	010	080	89	69	21.5	32	69	49	57.7
			063	010	080	106	86	25.5	40	84	64	73.6

STROKE (1) Can be ordered in multiples of 10mm, between Min. and Max. values.

## F - AU FALSE CUT

Special Sizes Available On Request.

3D Insertion Reference

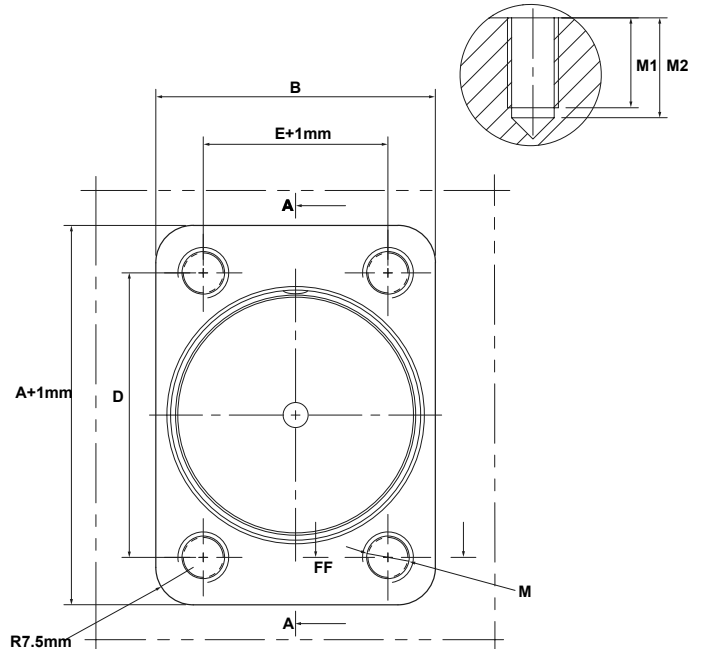
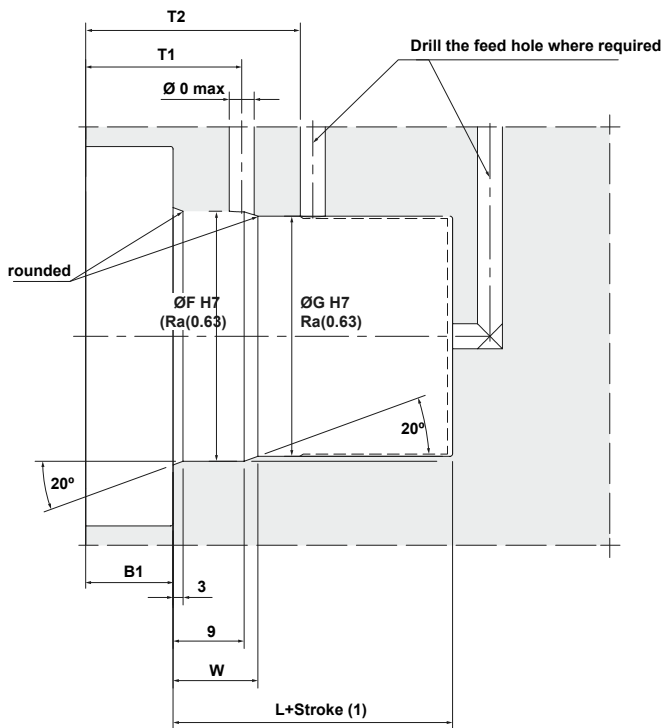

H ±0.5	L	M	M1	M2	$\varnothing O \text{ Max}$	P	Q	S	T1	T2 Min	U	V	W	X	Y
10	23.5	M5x20	12	15	6	13	35.4	3	13.5	28	3	9	16	24.4	M10x15
12	24.5	M6x20	13	16	7	17	42.1	4	13.5	29	3	9	17	25.4	M12x15
13	26	M8x25	16	19	8	21	50.1	4	13.5	20	3	9	17	25.4	M16x25
14	30.5	M10x30	19	21	10	26	59.7	5	15	32	3	9	19	27.4	M20x30
18	34	M12x30	19	21	10	32	75.1	5	16	32	3	9	19	27.4	M24x35